

ZECA

Z

TECHNICAL EXCELLENCE. SINCE 1929.

INDUSTRIAL CABLE REELS SERIES 4000

ART. 4116

Length (m)
11

Number of conductors
1 X

Cross-section (mm²)
16



TECHNICAL DATA

Article	Cable length (m)	Reel cable length (m)	Cut length (m)	Number of conductors	Cross-section (mm ²)	Cable diameter (mm)	Thermal switch	Cable type
4116	11	10	1	1 X	16	8	NO	PVC

Please note: The images are for illustrative and explanatory purposes only

OVERALL DIMENSIONS

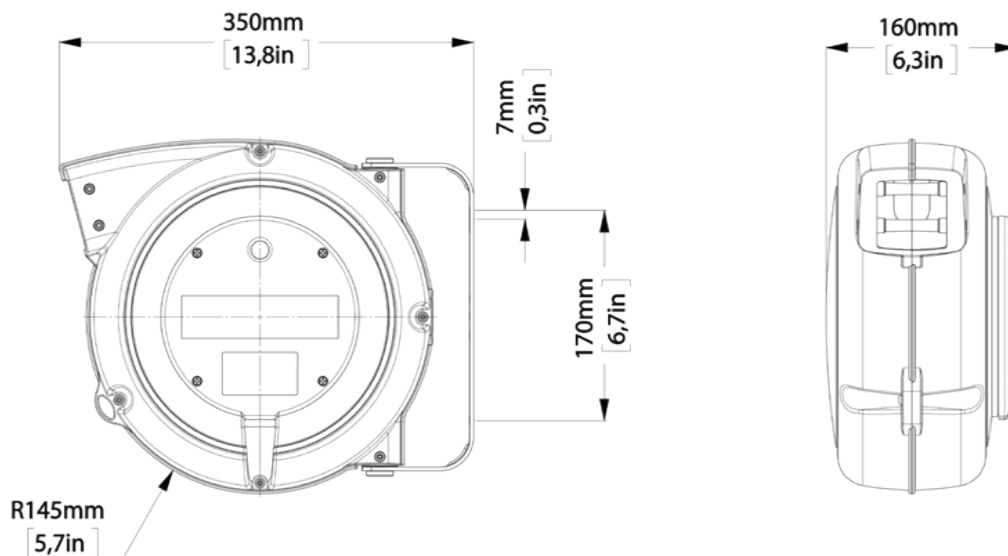

Technical features

- Structural elements of the winder in shockproof plastic.
- Roller cable guide mouth.
- Cable stop device with rack that can be inserted every 50 cm. Easily eliminated if the cable is constantly in traction.
- Double ground contact.
- Collector insulation voltage 2.5 KV.
- Sliding contacts with collector ring and brushes.
- Degree of protection IP42.
- Supplied without piece on the power supply side.
- Models with both PVC and rubber cables are available.
- Ambient temperature of use: -5 ° / + 50 °.

OPTIONAL ACCESSORIES AND SPARE PARTS

ART. 949/804-4000

for winder 4000

Optional device to make the hose reel fixed instead of swiveling.

Indispensable for ceiling application.