

ZECA

TECHNICAL EXCELLENCE. SINCE 1929.

INDUSTRIAL CABLE REELS SERIE 9000

ART. 9002

Length (m)
6

Number of conductors
2 X

Cross-section (mm²)
1.5

Wound cable capacity (@20°C)
1,4 KW @ 230V

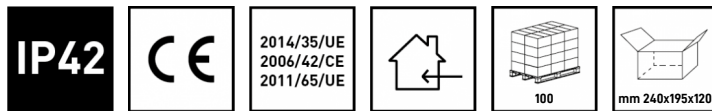

TECHNICAL DATA

Article	Cable length (m)	Reel cable length (m)	Cut length (m)	Number of conductors	Cross-section (mm ²)	Wound cable capacity (@20°C)	Unwound cable capacity (@20°C)	Cable diameter (mm)	Thermal switch	V max	Cable type
9002	6	5	1	2 X	1.5	1,4 KW @ 230V	1,9 KW @ 230V	8	YES	500	PVC

Please note: The images are for illustrative and explanatory purposes only

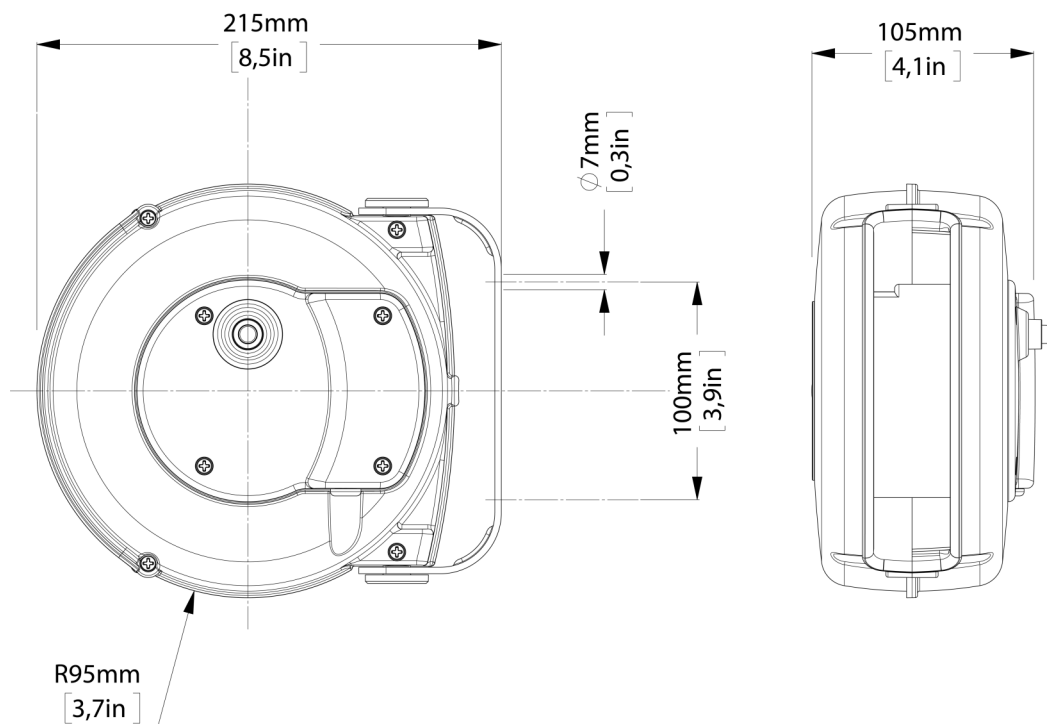
OVERALL DIMENSIONS**Technical features**

- Small size.
- External structure in shockproof plastic.
- Cable stop device with rack that can be inserted every 50cm. The stopping device can be easily removed if the cable is to be constantly pulled.
- Ambient temperature of use: -5 ° C / + 50 ° C.
- Sliding contacts with collector ring and brushes.
- Degree of protection IP42.
- Double ground contact.
- Collector insulation voltage 2.5 KV.
- Supplied without piece on the power supply side.